

---

IEC  
Installation  
Guide



## Installation and Safety Instructions IEC version

THIS DOCUMENT APPLIES TO THE FOLLOWING OPENAX PHOTOVOLTAIC MODULES:

### SINGLE GLASS MODULES

#### Half-Cut Technology series :

80 Half-Cut Cell Monocrystalline Silicon Modules  
OX-xxx-M10HC80-01(xxx=380-410),  
OX-xxx-M10HCB80-01(xxx=380-410)

90 Half-Cut Cell Monocrystalline Silicon Modules  
OX-xxx-M10HC90-01(xxx=430-460),  
OX-xxx-M10HCB90-01(xxx=430-460)

100 Half-Cut Cell Monocrystalline Silicon Modules  
OX-xxx-M10HC100-01(xxx=480-510),  
OX-xxx-M10HCB100-01(xxx=480-510),

108 Half-Cut Cell Monocrystalline Silicon Modules  
OX-xxx-M10HC108-01(xxx=390-420),  
OX-xxx-M10HCB108-01(xxx=390-420)  
OX-xxx-M10HC108-01(xxx=520-560),  
OX-xxx-M10HCB108-01(xxx=520-560)

110 Half-Cut Cell Monocrystalline Silicon Modules  
OX-xxx-M10HC110-01(xxx=525-565),  
OX-xxx-M10HCB110-01(xxx=525-565)

120 Tri-Cut Cell Monocrystalline Silicon Modules  
OX-xxx-M10T120-01(xxx=380-415),  
OX-xxx-M10TB120-01(xxx=380-415)  
OX-xxx-M10T120-01(xxx=480-520),  
OX-xxx-M10TB120-01(xxx=480-520)

120 Half-Cut Cell Monocrystalline Silicon Modules  
OX-xxx-M10HC120-01(xxx=340-390),  
OX-xxx-M10HCB120-01(xxx=340-390),  
OX-xxx-M10HC120-01(xxx=430-470),  
OX-xxx-M10HCB120-01(xxx=430-470),  
OX-xxx-M10HC120-01(xxx=480-520),  
OX-xxx-M10HCB120-01(xxx=480-520),  
OX-xxx-M10HC120-01(xxx=580-620),  
OX-xxx-M10HCB120-01(xxx=580-620)

132 Half-Cut Cell Monocrystalline Silicon Modules  
OX-xxx-M10HC132-01(xxx=485-510),  
OX-xxx-M10HCB132-01(xxx=485-510),  
OX-xxx-M10HC132-01(xxx=480-520),  
OX-xxx-M10HCB132-01(xxx=480-520),  
OX-xxx-M10HC132-01(xxx=630-680),  
OX-xxx-M10HCB132-01(xxx=630-680)

144 Half-Cut Cell Monocrystalline Silicon Modules  
OX-xxx-M10HC144-01(xxx=410-470),  
OX-xxx-M10HCB144-01(xxx=410-470),  
OX-xxx-M10HC144-01(xxx=520-560),  
OX-xxx-M10HCB144-01(xxx=520-560)

156 Half-Cut Cell Monocrystalline Silicon Modules  
OX-xxx-M10HC156-01(xxx=560-610),  
OX-xxx-M10HCB156-01(xxx=560-610)

150 Tri-Cut Cell Monocrystalline Silicon Modules  
OX-xxx-M10-T156-01(xxx=480-520),  
OX-xxx-M10-TB156-01(xxx=480-520)

#### Shingled Technology series :

44 Shingled Cell Monocrystalline Modules  
OX-xxx-M10SHG44-01(xxx=390-430)

46 Shingled Cell Monocrystalline Modules  
OX-xxx-M10SHG46-01(xxx=420-450)

58 Shingled Cell Monocrystalline Modules  
OX-xxx-M10SHG58-01(xxx=530-560), OX-xxx-M10SHG-  
B58-01(xxx=530-560)

60 Shingled Cell Monocrystalline Modules  
OX-xxx-M10SHG60-01(xxx=385-420)

69 Shingled Cell Monocrystalline Modules  
OX-xxx-M10SHG69-01(xxx=635-670),  
OX-xxx-M10SHGB69-01(xxx=635-670),

72 Shingled Cell Monocrystalline Modules  
OX-xxx-M10SHG72-01(xxx=460-505),  
OX-xxx-M10SHGB72-01(xxx=460-505)

---

**TOPCon Technology series :**

96 Half-Cut Cell N-Type Monocrystalline Modules (TOPCon)  
OX-xxx-M10TC96-01(xxx=480-510),  
OX-xxx-M10TCB96-01(xxx=480-510)

108 Half-Cut Cell N-Type Monocrystalline Modules (TOPCon)  
OX-xxx-M10TC108-01(xxx=410-440),  
OX-xxx-M10TCB108-01(xxx=410-440),  
OX-xxx-M10TC108-01(xxx=550-580),  
OX-xxx-M10TCB108-01(xxx=550-580)

120 Half-Cut Cell N-Type Monocrystalline Modules (TOPCon)  
OX-xxx-M10TC120-01(xxx=460-490),  
OX-xxx-M10TCB120-01(xxx=460-490),  
OX-xxx-M10TC120-01(xxx=490-505),  
OX-xxx-M10TCB120-01(xxx=490-505),  
OX-xxx-M10TC120-01(xxx=480-520),  
OX-xxx-M10TCB120-01(xxx=480-520),  
OX-xxx-M10TC120-01(xxx=610-650),  
OX-xxx-M10TCB120-01(xxx=610-650)

132 Half-Cut Cell N-Type Monocrystalline Modules (TOPCon)  
OX-xxx-M10TC132-01(xxx=480-520),  
OX-xxx-M10TCB132-01(xxx=480-520),  
OX-xxx-M10TC132-01(xxx=500-520),  
OX-xxx-M10TCB132-01(xxx=500-520),  
OX-xxx-M10TC132-01(xxx=500-540),  
OX-xxx-M10TCB132-01(xxx=500-540),  
OX-xxx-M10TC132-01(xxx=670-710),  
OX-xxx-M10TCB132-01(xxx=670-710)

144 Half-Cut Cell N-Type Monocrystalline Modules (TOPCon)  
OX-xxx-M10TC144-01(xxx=550-590),  
OX-xxx-M10TCB144-01(xxx=550-590)

---

**DOUBLE GLASS MODULES :**

---

**Half-Cut Technology series :**

80 Half-Cut Cell Monocrystalline Silicon Modules  
OX-xxx-M10HCBV80-01(xxx=380-410),  
OX-xxx-M10HCBVB80-01(xxx=380-410)

100 Half-Cut Cell Monocrystalline Silicon Modules  
OX-xxx-M10HCBV100-01(xxx=475-510),  
OX-xxx-M10HCBVB100-01(xxx=475-510)

108 Half-Cut Cell Monocrystalline Silicon Modules  
OX-xxx-M10HCBV108-01(xxx=390-420),  
OX-xxx-M10HCBVB108-01(xxx=390-420)

110 Half-Cut Cell Monocrystalline Silicon Modules  
OX-xxx-M10HCBV110-01(xxx=525-565),  
OX-xxx-M10HCBVB110-01(xxx=525-565)

120 Tri-Cut Cell Monocrystalline Silicon Modules  
OX-xxx-M10TBV120-01(xxx=380-415),  
OX-xxx-M10TBVB120-01(xxx=380-415),  
OX-xxx-M10TBV120-01(xxx=495-510),  
OX-xxx-M10TBVB120-01(xxx=495-510)

120 Half-Cut Cell Monocrystalline Silicon Modules  
OX-xxx-M10HCBV120-01(xxx=435-470),  
OX-xxx-M10HCBVB120-01(xxx=435-470),  
OX-xxx-M10HCBV120-01(xxx=570-615),  
OX-xxx-M10HCBVB120-01(xxx=570-615),  
OX-xxx-M10HCBV120-01(xxx=485-510),  
OX-xxx-M10HCBVB120-01(xxx=485-510)

132 Half-Cut Cell Monocrystalline Silicon Modules  
OX-xxx-M10HCBV132-01(xxx=475-515),  
OX-xxx-M10HCBVB132-01(xxx=475-515),  
OX-xxx-M10HCBV132-01(xxx=635-675),  
OX-xxx-M10HCBVB132-01(xxx=635-675)

144 Half-Cut Cell Monocrystalline Silicon Modules  
OX-xxx-M10HCBV144-01(xxx=520-560),  
OX-xxx-M10HCBVB144-01(xxx=520-560)

150 Tri-Cut Cell Monocrystalline Silicon Modules  
OX-xxx-M10TBV150-01(xxx=480-520),  
OX-xxx-M10TBVB150-01(xxx=480-520)

---

**Shingled Technology series :**

58 Shingled Cell Monocrystalline Modules  
OX-xxx-M10SHGBV58-01(xxx=530-560)

69 Shingled Cell Monocrystalline Modules  
OX-xxx-M10SHGBV69-01(xxx=640-680)

---

### TOPCon Technology series :

96 Half-Cut Cell N-Type Monocrystalline Modules (TOPCon)  
OX-xxx-M10TCBV96-01(xxx=480-510)

108 Half-Cut Cell N-Type Monocrystalline Modules (TOPCon)  
OX-xxx-M10TCBV108-01(xxx=410-440),  
OX-xxx-M10TCBVB108-01(xxx=410-440),  
OX-xxx-M10TCBV108-01(xxx=485-510),  
OX-xxx-M10TCBVB108-01(xxx=485-510),  
OX-xxx-M10TCBV108-01(xxx=550-580),  
OX-xxx-M10TCBVB108-01(xxx=550-580)

120 Half-Cut Cell N-Type Monocrystalline Modules (TOPCon)  
OX-xxx-M10TCBV120-01(xxx=460-490),  
OX-xxx-M10TCBV120-01(xxx=485-510)  
OX-xxx-M10TCBV120-01(xxx=610-650)

132 Half-Cut Cell N-Type Monocrystalline Modules (TOPCon)  
OX-xxx-M10TCBV132-01(xxx=485-510)  
OX-xxx-M10TCBV132-01(xxx=500-540),  
OX-xxx-M10TCBV132-01(xxx=670-710),  
OX-xxx-M10TCBVB132-01(xxx=670-710)

144 Half-Cut Cell N-Type Monocrystalline Modules (TOPCon)  
OX-xxx-M10TCBV144-01(xxx=550-590)

156 Half-Cut Cell N-Type Monocrystalline Modules (TOPCon)  
OX-xxx-M10TCBV156-01(xxx=590-640)

---

### Heterojunction Technology series :

108 Half-Cut Cell HJT Monocrystalline Silicon Modules  
OX-xxx-HJTBV108-01(xxx=410-440),  
OX-xxx-HJTBVB108-01(xxx=410-440)

110 Half-Cut Cell HJT Monocrystalline Silicon Modules  
OX-xxx-HJTBV110-01(xxx=550-590)

120 Half-Cut Cell HJT Monocrystalline Silicon Modules  
OX-xxx-HJTBV120-01(xxx=365-420),  
OX-xxx-HJTBV120-01(xxx=485-520),  
OX-xxx-HJTBV120-01(xxx=500-520),  
OX-xxx-HJTBVB120-01(xxx=600-645)

132 Half-Cut Cell HJT Monocrystalline Silicon Modules  
OX-xxx-HJTBV132-01(xxx=400-450),  
OX-xxx-HJTBV132-01(xxx=485-520),  
OX-xxx-HJTBV132-01(xxx=500-520),  
OX-xxx-HJTBVB132-01(xxx=670-710)

144 Half-Cut Cell HJT Monocrystalline Silicon Modules  
OX-xxx-HJTBV144-01(xxx=450-490),  
OX-xxx-HJTBV144-01(xxx=550-590)

## Table of Contents

<b>1. INTRODUCTION</b>	<b>6</b>
How to use the manual	6
General guidelines	6
Handling safety	7
Installation safety	8
Fire safety	9
<b>2. PRODUCT IDENTIFICATION</b>	<b>9</b>
<b>3. UNLOAD / TRANSPORTATION / STORAGE</b>	<b>10</b>
Unloading	11
Secondary transportation	13
Storage	14
<b>4. UNPACKING</b>	<b>14</b>
Unpacking Safety	14
Unpacking for vertical landscape package	16
Unpacking for modules with vertical portrait package	17
<b>5. MECHANICAL INSTALLATION</b>	<b>18</b>
Selecting the location	18
General installation guidelines	19
Environmental conditions	19
Installation method	20
Attachment guidelines	22
<b>6. ELECTRICAL INSTALLATION</b>	<b>26</b>
General installation guidelines	26
Cables, Connectors and Junction Box	27
Grounding	28
<b>7. ELECTRICAL CONFIGURATION</b>	<b>31</b>
Fuse	32
Inverter Selection and Compatibility	32
Bypass diodes	32
<b>8. MODULE SPECIFICATIONS</b>	<b>33</b>
<b>9. MAINTENANCE &amp; CLEANING</b>	<b>33</b>
Visual inspection	33
Cleaning	34
<b>10. DISCLAIMER OF LIABILITY</b>	<b>36</b>
<b>11. DECOMMISSIONING AND RECYCLING</b>	<b>36</b>
<b>12. PRODUCT INFORMATION</b>	<b>36</b>

### 1.INTRODUCTION

Thank you for selecting OPENAX Photovoltaic Modules. The OPENAX Photovoltaic Modules are designed and manufactured to the highest quality standards. With correct installation and maintenance, OPENAX modules will keep providing clean energy for many years.

#### How to use this manual

- ☑ This manual contains information regarding the installation and safe handling of OPENAX photovoltaic modules (hereafter referred to as “modules”), manufactured by OPENAX, hereafter referred to as “OPENAX”.
- ☑ Installers must read and understand this guide prior to installation. For any questions, please contact our Global Quality & Customer Support department for further information. Installers should follow all safety precautions described in this guide as well as local codes when installing a module.
- ☑ Before installing a solar photovoltaic system, installers should familiarize themselves with its mechanical and electrical requirements. Keep this guide in a safe place for future reference (operation and maintenance) and in case of sale or disposal of the modules.

#### WARNING :



For your safety and the safety of others, please read the entire Installation, operation and maintenance manual carefully prior to installing, wiring, operating and performing maintenance of PV modules. Also, carefully read the Module Data Sheet provided with this product. Determine local permits, installation and inspection requirements before installing module(s). If not otherwise specified, it is recommended that the requirements of the regional & National Electric Code (NEC) be followed.

#### General Guidelines

- ☑ Installing solar photovoltaic systems requires specialized skills and knowledge. Installation should only be performed by qualified persons.
- ☑ Installers should assume all risks of injury that might occur during installation, including, but not limited to, the risk of electric shock.
- ☑ One single module may generate more than 30V DC when exposed to direct sunlight. Contact with a DC voltage of 30V or more is potentially hazardous.
- ☑ Our module application class is class A, modules rated for use in this application class may be used in systems operating at greater than 50V DC or 240W, where general contact access is anticipated.
- ☑ Do not disconnect under load.
- ☑ OPENAX’s Bifacial Modules produce Voltage when exposed to light also on backside.
- ☑ Photovoltaic solar modules convert light energy to direct current electrical energy. They are designed for outdoor use. Modules can be ground mounted, mounted on rooftops, vehicles or boats. The proper design of support structures lies within responsibility of the system designers and installers.

- ☑ Do not use mirrors or other magnifiers to concentrate sunlight onto the modules. Artificially concentrated light shall not be directed on the modules.
- ☑ When installing the system, abide to all local, regional and national statutory regulations. Obtain a building permit if necessary.
- ☑ Under standard test conditions, the electrical characteristics are within  $\pm 5$  percent of the indicated values of  $I_{sc}$  and  $V_{oc}$  (irradiance of  $1000\text{W}/\text{cm}^2$ , AM 1.5 spectrum, cell temperature  $25^\circ\text{C}$ ).
- ☑ Only use equipment, connectors, wiring and support frames suitable for solar electric systems.
- ☑ For modules under IEC investigation, under normal conditions, a solar photovoltaic module is likely to Experience conditions that produce more current and/or voltage than reported at standard test conditions. Accordingly, the values of  $I_{sc}$  and  $V_{oc}$  marked on this module should be multiplied by a factor of 1.25 when determining component voltage ratings, conductor current ratings, fuse sizes and size of controls connected to the PV output.

### Handling Safety



#### CAUTION :

To avoid the hazard of electric shock and injury when installing, wiring, operating and maintaining the PV modules, below guidelines shall be strictly followed.

- ☑ Use appropriate protective measures (e. g., insulation gloves, safety shoes, etc.) to avoid direct contact with 30V DC or higher voltage and avoid accidental cuts with sharp edges during installation.
- ☑ Do not lift the module by grasping the module's junction box or electrical leads.
- ☑ Do not stand or step on the module.
- ☑ Do not drop the module or allow objects to fall on the module.
- ☑ To avoid glass breakage, do not place any heavy objects on the module.
- ☑ Be cautious when setting the module down on to a surface.
- ☑ Inappropriate transport and installation may break the module.
- ☑ Do not attempt to disassemble the modules, and do not remove any attached nameplates or components from the modules.
- ☑ Do not apply paint or adhesive to the module top surface.
- ☑ To avoid damage to the backsheet, do not scratch or hit the backsheet.
- ☑ Do not drill holes in the frame. This may compromise the frame strength and cause corrosion of the frame.
- ☑ Do not scratch the anodized coating of the frame (except for grounding connection). It may cause corrosion of the frame or compromise the frame strength.

- ☑ Be careful when setting the panel down onto a surface, particularly when placing it on a corner.
- ☑ A panel with broken glass or torn backsheet cannot be repaired and must not be used since contact with any panel surface or the frame can cause an electric shock.
- ☑ Work only under dry conditions, and use only dry tools. Do not handle panels when they are wet unless wearing appropriate protective equipment.
- ☑ When storing uninstalled panels outdoors for any period of time, always cover the panels and ensure that the glass faces upwards to stop water from collecting inside the panel and causing damage to exposed connectors.

---

### Installation Safety

- ☑ Never open electrical connections or unplug connectors while the circuit is under load.
- ☑ Contact with electrically charged parts of the panels, such as terminals, can result in burns, sparks and lethal shock whether or not the panel is connected.
- ☑ Do not touch the PV module unnecessarily during installation. The glass surface and the frame may be hot; there is a risk of burns and electric shock.
- ☑ Do not work in the rain, snow or in windy conditions.
- ☑ Avoid exposing cables to direct sunlight in order to prevent their degradation.
- ☑ Keep children well away from the system while transporting and installing mechanical and electrical components.
- ☑ Completely cover the module with an opaque material during installation to prevent electricity from being generated.
- ☑ Do not wear metallic rings, watchbands, ear, nose, lip rings or other metallic objects while installing or troubleshooting photovoltaic systems.
- ☑ Use only insulated tools that are approved for working on electrical installations.
- ☑ Follow the safety regulations for all other system components, including wires and cables, connectors, charging regulators, inverters, storage batteries, rechargeable batteries, etc.
- ☑ Only use connectors to connect modules to form a string, or connect to another device. Removing the module connectors will render the warranty void.



---

## Fire Safety

- ☑ In the case of a fire, PV modules may produce dangerous voltage/surge current, even if they have been disconnected from the inverter, or have been partly or entirely destroyed, or the naked wiring destroyed. In the event of fire, inform the fire/safety team about the particular hazards from the PV system, and stay away from all elements of the PV system during and after a fire until the necessary steps have been taken to mitigate the risk.
- ☑ Consult your local authority for guidelines and requirements for building or structural fire safety.
- ☑ Roof constructions and installations may affect the fire safety of a building; improper installation may create hazards in the event of a fire.
- ☑ Use components such as ground fault circuit breakers and fuses as required by local authority.
- ☑ Do not use panels near equipment or in places where flammable gases may be generated.
- ☑ The modules have been rated Fire Class C, and are suitable for mounting onto a fire retardant roof covering rated for the application at a minimum distance of 10 cm from the panel to the roof plane.
- ☑ Any module or panel mounting system has limitations on specific inclination required to maintain a specific System Fire Class C Rating.
- ☑ The fire rating of the module is valid only when mounted in the manner specified in the mechanical mounting instructions.
- ☑ A minimum slope of 5 in/ft. for installation over a roof is required to maintain the fire class C rating. Refer to your local authority for guidelines and requirements for building or structural fire safety. For roof application, the Modules should be mounted over a fire resistant covering rated for the application.
- ☑ Ensure that all connections are securely made with no gap between the contacts. Any gap can result in electrical arcing that can cause a fire hazard and/or an electric shock.
- ☑ Do not use water to extinguish the fire if the power supply is not disconnected.

## 2. PRODUCT IDENTIFICATION

### Nameplate label

Each module has label providing the following information:

The product type, rated power, rated current, rated voltage, open circuit voltage, short circuit current, (all as measured under standard test conditions), weight, dimensions and the maximum system voltage. The nameplate is attached on the rear side of the module.

### 3. UNLOAD / TRANSPORTATION / STORAGE

Please make sure to have sufficient safe distance during forklift operation to prevent people from standing or passing on both sides.

When unloading using a forklift, particular care should be taken to control the travel speed and prevent tilting during cornering.

In any circumstances, for vertical landscape packages, it shall not be stacked more than two layers; for vertical portrait packages, stacking is not allowed.

The working ground needs to ensure that the packaging box can be placed horizontally and steadily to avoid tipping.

Example for vertical landscape package and vertical portrait package is shown as follows:

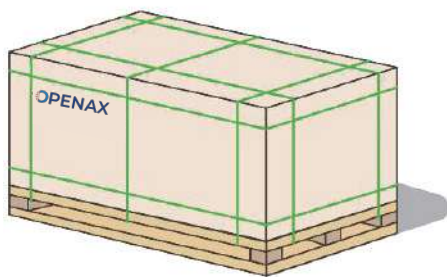

Vertical landscape package  
(short-side vertically placed)

---



Vertical portrait package  
(long-side vertically placed)

---

### Unloading

#### Crane unloading :

When crane is used to unload the modules, choose and use specific adapted tooling to the weight and size of the modules.

Adjust the position of the sling to keep the modules steady.

To ensure the safety of the modules, wooden sticks, boards or other fixtures of the same width as the outer packing cases should be used on the upper part of the box, to prevent the sling from squeezing the pallet and damaging the modules.

When placing the modules, do not lower the packing box too quickly and put it on a flat ground.

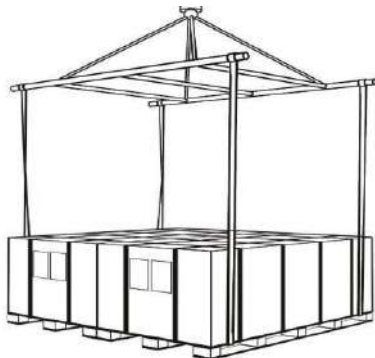

#### Forklift unloading :

Use the forklift to remove the modules from the truck. The forklift does not impact the packing box during loading or unloading. Select a forklift with a large enough lift weight, and the depth of the fork insertion tray shall not be less than three-quarters of the length of the tray.

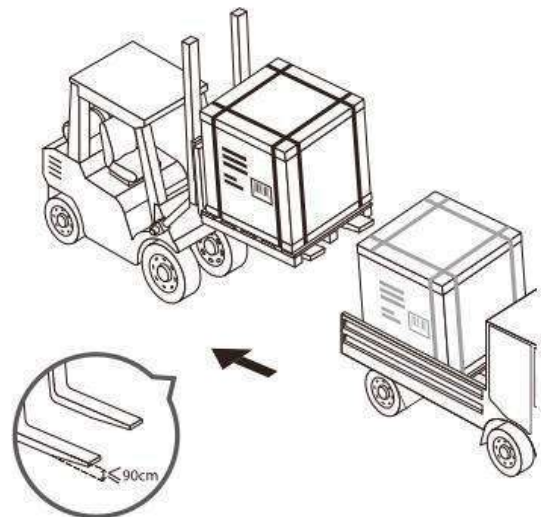

Prevent collision on the top when unloading from the container.

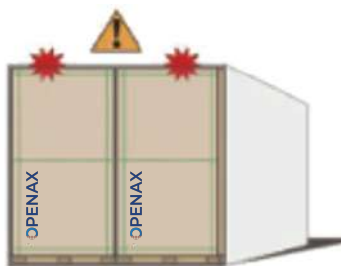

Recommend to secure the module package to the forklift with a safety rope, transport horizontally with no person standing on either side.

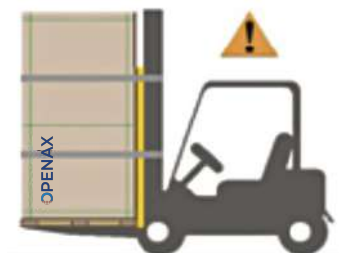

Place the modules on the horizontal ground.

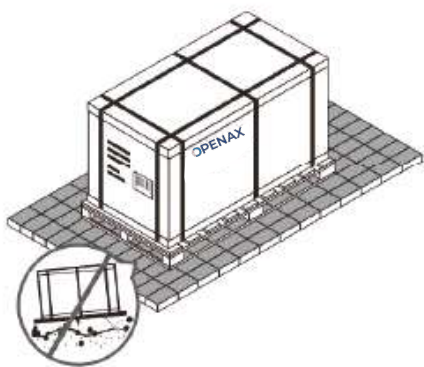

No stacking of modules in the project site.

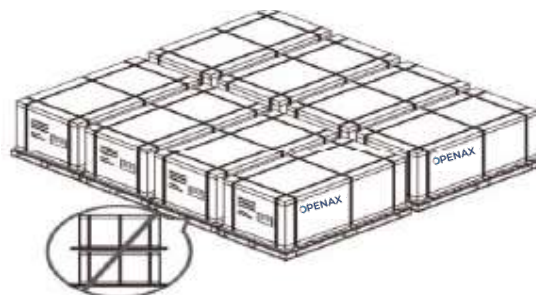

The pallets must be placed in a ventilated and dry place.



Cover the assembly with rain cloth to prevent damp damp.



### Secondary transportation

Do not remove the original package and keep the wrapping film and carton box in a good condition, if the modules require long-distance transport or longterm storage



The packaged modules can be transported by land, sea or air. During transportation, make sure that the package is fixed with packing belts securely on the shipping platform without any movement. (Take land transport, for example.)

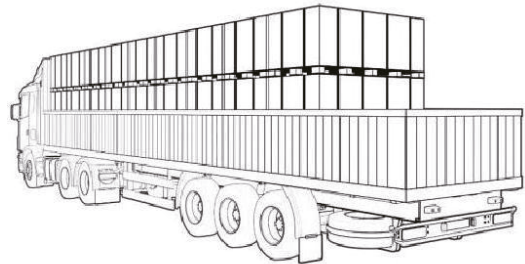

Do not open the original package. Please secure the box on the transportation platform to ensure that the box is firmly fixed.

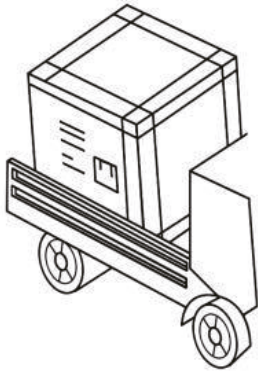

The use of a tricycle for the transfer of unpacked modules is prohibited

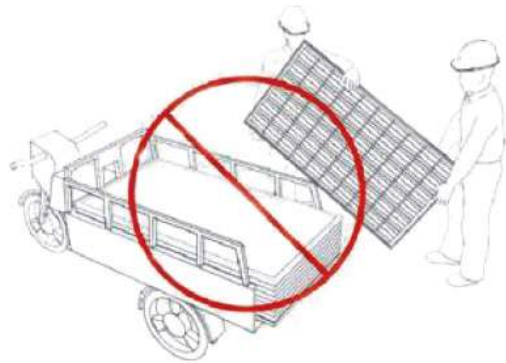

Do not back the assembly with a rope.

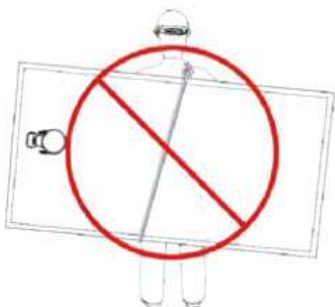

Single person backing module is prohibited.



### Storage

- ☑ Do not expose the modules to rain or wet conditions and need to be stored in a dry and ventilated environment.
- ☑ Place modules on relatively flat ground to avoid package damage or dumping due to deformation or collapse of the ground.
- ☑ When the module is stored in the warehouse in the project site, please ensure that the storage environment requirements: the humidity is <85%, the temperature range is -40°C ~ + 50°C, and the module static stack code is stacked in 1 box.
- ☑ Do not remove the original package and keep the wrapping film and carton box in a good condition, if the modules require long-distance transport or long-term storage.

## 4. UNPACKING

### Before unpacking,

- ☑ Check the product type, power bins, serial number and relevant suggestions on the A4 paper of the packaging box, and read the unpacking instructions carefully.
- ☑ Custom unpacking methods are prohibited.
- ☑ Make sure that the packaging box is in good condition, it is recommended to use art knife to remove the packing belt and wrapping film. Violent removal is prohibited to avoid scratching the modules in the box.
- ☑ Check that the number of modules in the box and the barcode information on the module frame are consistent with the information on the A4 paper on the packaging box.
- ☑ Follow the recommended unpacking steps to unpack the modules. When unpacking, it must be operated by two or more people at the same time. Always wear insulating gloves when handling the modules.

If all the modules are not taken out after unpacking, the remaining modules shall be placed horizontally and repackaged to prevent them from tipping. When packaging, please note that the glass side of the bottom module should face up, the glass side of the middle modules should face down, and the glass side of the top module should face up.

Stacks of modules should contain no more than 12 modules, and the frames should be aligned.

### Unpacking Safety

- ☑ In windy weather, it is recommended not to carry the modules, and the unpacked modules should be properly secured.
- ☑ Do not unpack the modules outside under rain and snow conditions.
- ☑ Do not carry the module by one person to prevent the module from slipping and hitting other modules, causing scratches, cracks, or deformation on the modules.
- ☑ Do not lift modules by their cables or junction box.
- ☑ Before removing the inner packing belts, please take measures to protect the modules from dumping.

- ☑ If unpacking the vertical landscape packages on non-horizontal ground, anti-tilting measures should be taken.
- ☑ The vertical portrait packages have a high center of gravity and are prohibited to unpack on non-horizontal or soft grounds to avoid personal injury or even death.
- ☑ When unpacking vertical portrait package, do not stand on the back of the stand supporter, please operate in strict accordance with the requirements of the unpacking instructions.
- ☑ When removing the packing belts in vertical portrait package, take care not to hurt yourself (face, eyes, etc.).
- ☑ Do not stand on the pallet during unpacking, please carry the modules from sides of the pallet.
- ☑ Do not move the stand supporter during unpacking to prevent the modules being tilted.
- ☑ Do not lean the module on any instable objects, such as poles or mounting columns.
- ☑ Do not support the back of the modules directly with materials such as wooden strips.

### Unpacking for Vertical landscape package

1

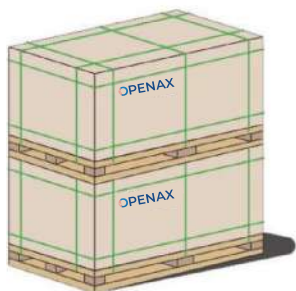

2

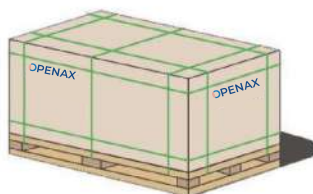

3

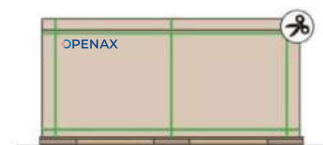

1. Remove the wrapping film and packing belts.
2. Single layer for unpacking.
3. Cut off the outer packing belt of cardboard.

4



5

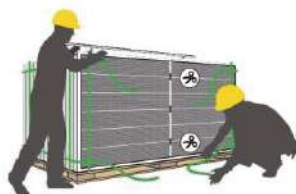

6



4. Remove the top cover and the cartons.
5. Cut off all the horizontal packing.
6. when there are 1 or 2 vertical packing belts remaining, push the module gently to tilt toward the stand supporter.

6



7

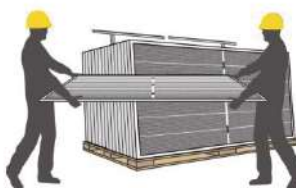

7. Cut off the remaining packing belts.
8. Take out the modules in order.



### Unpacking for modules with vertical portrait package

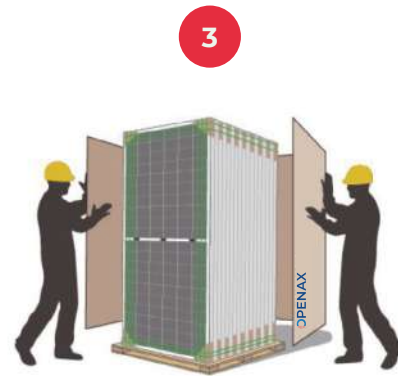
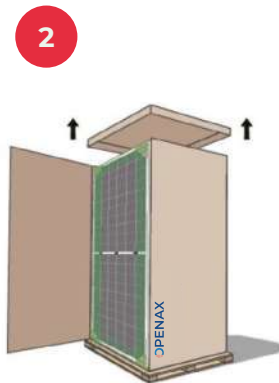
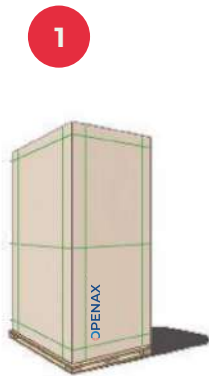

1. Remove the wrapping film and packing belts.
2. Remove the top cover and sealing tape.
3. Remove the carton box.



4. Place the stand supporter from the glass or backsheet side.
5. Cut off all the horizontal packing belts.
6. When there are 1-2 vertical packing belts remaining, push the module gently to tilt toward the stand supporter.



7. Cut off the remaining packing belts so that the modules rest on the stand supporter.
8. Take out the module in order.

## 5. MECHANICAL INSTALLATION

### Selecting the location

- ☑ Select a suitable location for installing the modules.
- ☑ Consult local codes and other applicable laws concerning required permits on regulations concerning installation and inspection requirements.
- ☑ Before installing a PV module, contact appropriate authorities to determine permit, installation and inspection requirements that should be followed.
- ☑ Install PV modules and ground frame in accordance with applicable rules and regulations.
- ☑ The modules should be facing south in northern latitudes and north in southern latitudes.
- ☑ For detailed information on the best installation angle, refer to standard solar photovoltaic installation guides or consult a reputable solar installer or systems integrator.
- ☑ The module should not be continuously shaded.
- ☑ Do not install modules near equipment or in locations where flammable gases may be generated or collected.
- ☑ Do not install modules under water or in continuous contact with water.
- ☑ Do not install modules in locations where they may be exposed to sulfur or harmful, corrosive chemicals.
- ☑ Do not install modules in environments with excessive dust, sand, salt mist or pollution.

### \*Specific BIFACIAL Modules

- ☑ Output power is increased proportionally to the light received by rear side of modules.
- ☑ The available light that hits the back of the module is directly related to the height (and tilt angle) of the module installed over the surface.
- ☑ Choose the highest possible Surface Reflectivity/Albedo, such as a white roof or white ground surface covering.



#### DESERT SAND

- ☑ Albedo 22-25%
- ☑ Expected yield gain 15-10%



#### GREEN GRASS GRAVEL

- ☑ Albedo 10-20%
- ☑ Expected yield gain 6-7%



#### SNOW / WHITE PAINT

- ☑ Albedo 80-95%
- ☑ Expected yield gain 15-25%

- ☑ Avoid shading the back side of the module by the support rack.
- ☑ Elevate the modules above the mounting surface at an appropriate height to avoid loss of irradiance.
- ☑ With tilted rooftop installation, ensure an appropriate ventilation on back to reduce an accumulation of heat with adverse effects on the performance.
- ☑ It is recommended that a proper simulation is carried out before setting up a power plant.

### General Installation Guidelines

- ☑ The module mounting structure must be made of durable, corrosion-resistant and UV-resistant material.
- ☑ In regions with heavy snowfall in winter, select the height of the mounting system so that the lowest edge of the module is not covered by snow for any length of time. The maximum altitude of the PV module is designed for  $\leq 2000\text{m}$ .
- ☑ In addition, ensure that the lowest portion of the module is placed high enough so that it is not shaded by plants or trees or damaged by flying sand.
- ☑ The modules must be securely attached to the mounting structure.
- ☑ Provide adequate ventilation under the modules in conformity to your local regulations. A minimum distance of 10 cm between the roof plane and the frame of the module is generally recommended.
- ☑ Always observe the instructions and safety precautions included with the module support frames.
- ☑ Do not attempt to drill holes in the glass surface of the modules as this will void the warranty.
- ☑ Do not drill additional mounting holes in the frames of the modules as this will void the warranty.
- ☑ Before installing modules on a roof, ensure that the roof construction is suitable. In addition, any roof penetration required to mount the module must be properly sealed to prevent leaks.
- ☑ When installing a module on a pole, choose a pole and module mounting structure that will withstand the anticipated winds for the area.
- ☑ Dust building up on the surface of the module can impair module performance.
- ☑ OPENAX recommends installing the modules with a tilt angle of at least 10 degrees, making it easier for dust to be washed off by rain.
- ☑ Observe the linear thermal expansion of the module frames (the recommended minimum distance between two modules 2 cm).
- ☑ Always keep the backsheet of the module free from foreign objects or structural elements, which could come into contact with the panel, especially when the module is under mechanical load.
- ☑ Ensure modules are not subjected to wind or snow loads exceeding the maximum permissible loads, and are not subject to excessive forces due to the thermal expansion of the support structures. See the following sections for more detailed information.

### Environmental conditions

- ☑ Ambient temperature:  $-40\text{ }^{\circ}\text{C}$  to  $+40\text{ }^{\circ}\text{C}$  ( $-40^{\circ}\text{F}$  to  $+104^{\circ}\text{F}$ ).
- ☑ Operating temperature:  $-40\text{ }^{\circ}\text{C}$  to  $+85\text{ }^{\circ}\text{C}$  ( $-40^{\circ}\text{F}$  to  $+185^{\circ}\text{F}$ ) IEC standards.
- ☑ Operating temperature:  $-40\text{ }^{\circ}\text{C}$  to  $+90\text{ }^{\circ}\text{C}$  ( $-40^{\circ}\text{F}$  to  $+194^{\circ}\text{F}$ ) UL61730 standards.
- ☑ Storage Temperature:  $-20^{\circ}\text{C}$  to  $+40^{\circ}\text{C}$ . ( $-4^{\circ}\text{F}$  to  $+104^{\circ}\text{F}$ ).
- ☑ Humidity:  $\leq 85\%$  RH.

- ☑ Mechanical Load Pressure: Maximum snow load 5400 Pa/ 0.783 psi which is equivalent to (550 Kg/m<sup>2</sup>) from the frontside.
- ☑ Wind load: Maximum 2400 pa / 0.348 psi which is equivalent to 240kg /m<sup>2</sup> from the rear side.
- ☑ Please consult PHS technical team for more information on the use of modules in special climates, such as an altitude greater than 2000 m.

### Installation Methods

The modules and racking system can be connected through the mounting holes, clamps, or an embedded system. Installation of modules must be carried out in accordance with the installation requirements. If you wish to use a different installation method, please consult OPENAX customer service or technical support team. If in such case that an alternative mounting method is used but not approved by OPENAX, the module may get damaged and the warranty will be invalidated.

- ☑ The module must always be mounted in the manner specified in these instructions.
- ☑ The module is considered to be in compliance with UL61703 only when the module is mounted in the manner specified by the mounting instructions.
- ☑ The modules can be installed on the frame using mounting holes, clamps or an insertion system. The modules must be installed according to the following examples. Not mounting the modules according to these instructions will void the warranty.
- ☑ The modules can be installed in both landscape and portrait modes.
- ☑ The modules must be properly secured to their support so that they can withstand live load conditions, including wind uplift or snow load, to the pressure they have been certified for. It is the installer's responsibility to ensure that the clamps used to secure the modules are strong enough and are made of corrosion-resistant materials.
- ☑ Be sure that the clamps overlap the module frame by at least 9mm and that they do not bend or distort the frame.
- ☑ The module clamps must not come into contact with the front glass or deform the frame in any way. Avoid shading effects from the module clamps and insertion systems. Drainage holes in the module frame must not be closed or obscured by the clamps.

Select the proper installation method depending on the mounting method and the load (See Fig. 1 for more detailed information).

### 1. Mounting with Bolts

The frame of each module has mounting holes, that are ideally placed to optimize the loading capacity to secure the modules on the supporting structure.

Each module needs to be tightened by at least two 4 points on the edge.

To maximize mounting longevity, OPENAX strongly recommends the use of corrosion proof (stainless steel) fixings. Bolts and nuts of M6 X 1.00 Grade 8.8 hot galvanized or A2-70 stainless steel shall be used.

The yield strength of the bolts and nuts shall not be less than 400 MPa. Tightening torque of M6 thick bolts is 15.8 - 23 N.M (11.65 - 16.9 ft.lb) according to the bolt grade.

The installation scheme in heavy snow or high wind load areas requires additional installation points. The system designer and installer have the responsibility to calculate the load and ensure that the support structure meets the requirements.

Refer to Fig. 1 for location of holes, installation methods and mechanical loads.

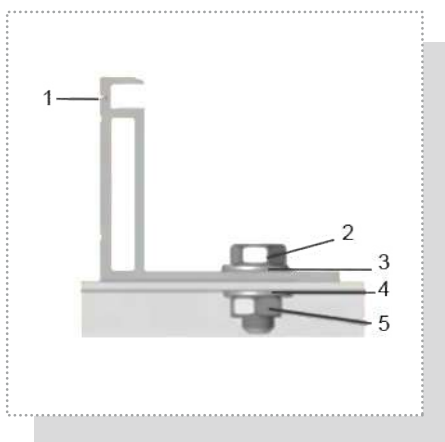

1. Aluminium Frame
2. M6 Stainless Steel bolts
3. Flat Stainless Steel washer
4. Spring Stainless Steel washer
5. HEX Stainless Nut

### 2 Mounting using clamps

The module may be fastened to the support frame by using clamps on the long or short side of the module frame.

It is recommended to use fixing bolt of at least M8. Be sure to ensure that the fixture does not fail due to deformation or corrosion during the overall loading of the assembly. The clamp shall not be malfunctioned due to deformation or corrosion during the loading process. It is recommended to use a clamp with length of  $\geq 50$  mm (1.97 inch) and thickness of  $\geq 3$  mm (0.12 inch).

The clamp must overlap the module frame by at least 8mm (0.32 inch) but not more than 10 mm (0.39 inch).

Module clamps should not come into contact with the front glass and must not be deformed.

Please make sure to avoid shading effects from the module clamps.

The module frame shall not to be modified under any circumstances.

When choosing clamp installation method, use at least four clamps on each module, two clamps should be attached on each long side of the module. Depending on local wind and snow loads, additional clamps may be required to ensure that modules can bear the extra load.

Applied torque should refer to mechanical design standard according to the bolt customer is using.

For example: M8 -> 16-20 N.m (140-180lb.in).

The installation method of clamps is shown below.



Installation of end clamp and middle clamp

Clamp positions are of crucial importance for the reliability of the installation. The clamp centerlines must only be positioned within the ranges indicated in table below (Fig. 1), depending on the configurations and loads.

### 3 Insertion system (rail)

The module may be mounted on the support by using an appropriate insertion system (rail) with or without additional clamps. The insertion system may fasten the long or the short side of the module frame. The installation requirements of the mounting system supplier must be strictly complied with. Refer to Fig. 1 for instructions.

### Attachment Guidelines

The mechanical loads described in this manual are the test loads. For calculating the equivalent maximum design loads, a safety factor of 1.5 needs to be considered in compliance with the requirements of the local laws and regulations. The design loads are strongly related to the construction, applied standards, location and local climate conditions; therefore, have to be determined by the racking suppliers and/or the professional engineers. For detailed information, please follow local structural code or contact your professional structural engineer.

The modules shall be mounted on continuous rails that extend beneath the modules. If modules are mounted without continuous rails, the maximum allowable load will be reduced.

☺ See below some Design loads equivalences.

<b>Static Mechanical Loading /Pa (Front/Back)</b>	<b>Design Mechanical Loading /Pa Safety factor = 1,5 (Front/Back)</b>
1800 / 1200	1200 / 800
3600 / 2400	2400 / 1600
5400 / 2400	3600 / 1600

☺ · Refer to Fig. 1 for the reference of installation methods applicable.

☺ Refer to Fig. 2 for the maximum test mechanical load values applicable to each module, and according to the installation methods.

☺ For specific requirement, please contact us : [info@power-benz.com](mailto:info@power-benz.com)

Mounting systems	Mounting rails perpendicular to the long side frame			Mounting rails parallel to long side frame		Mounting on the corners	
Mounting holes method					/	/	/
	Four mounting hole installation	Outer four mounting hole installation	Inner four mounting hole installation	Four mounting hole installation			
Four clamps mounting method			/				
	Clamping range [A]: [A] ≥ 1/6 Length -50mm [A] ≤ 1/4 Length +50mm	Clamping range [A]: [A] ≥ 0 mm [A] ≤ 1/5 Width +50mm		Clamping range [A]: [A] ≥ 1/6 Length -50mm [A] ≤ 1/4 Length +50mm	Clamping range [A]: [A] ≥ 0 mm [A] ≤ 1/5 Width +50mm		
	<b>4C1</b>	<b>4C2</b>		<b>4C3</b>	<b>4C4</b>	<b>4C5</b>	
Six clamps mounting method		/	/		/	/	/
	Clamping range [A]: 0 ≤ [A] ≤ 100 mm with 2 clamps in the middle of long side			Clamping range [A]: 0 ≤ [A] ≤ 100 mm with 2 clamps in the middle of long side			
Mounting system with insertion profil		/	/		/	/	/
	Use insertion profil on short side			Use insertion profil on long side			
	<b>IP1</b>			<b>IP2</b>			



Module Dimensions (mm)			Bolts mounting holes method				Clamps mounting method							Rail mounting method	
			Mounting rails cross the long frame			Mounting rails parallel the long frame	Mounting rails perpendicular to the long frame			Mounting rails parallel the long frame			Mounting on the corner	On long frame	
Length	Width	Thickness	H1	H2	H3	H4	4C1	4C2	6C1	4C3	4C4	6C2	4C5	IP1	IP2
			<b>Test load: Maximum static mechanical loads (Pa): i.e. Snow/Wind loads</b>												
≤ 1755	≤ 1038	30	+5400/-2400	/	/	+1800/-1800	+5400/-2400	+1000/-1000	/	+1800/-1800	+1800/-1800	/	+800/-800	+1000/-1000	+1800/-1800
≤ 2094	≤ 1038	30	+3600/-2400	/	/	+1800/-1800	+3600/-2400	/	+5400/-2400	+1800/-1800	+1800/-1800	/	/	/	+1800/-1800
≤ 1812	≤ 1096	30	+5400/-2400	/	/	+1800/-1800	+5400/-2400	+1000/-1000	/	+1800/-1800	+1800/-1800	/	+800/-800	+1000/-1000	+1800/-1800
≤ 1900	≤ 1096	30	+5400/-2400	/	/	+1600/-1600	+5400/-2400	/	/	+1600/-1600	+1600/-1600	+1800/-1800	/	/	+1800/-1800
≤ 2172	≤ 1096	30	+3600/-2400	-	-	+1600/-1600	+3600/-2400	/	+5400/-2400	+1600/-1600	+1600/-1600	+1800/-1800	/	/	+1800/-1800
≤ 1724	≤ 1134	30	+5400/-2400	/	/	+1600/-1600	+5400/-2400	+1000/-1000	/	+1600/-1600	+1600/-1600	+1800/-1800	+800/-800	+1000/-1000	+1800/-1800
≤ 1910	≤ 1134	30	+5400/-2400	/	/	+1600/-1600	+5400/-2400	/	/	+1600/-1600	+1600/-1600	+1800/-1800	/	/	+1800/-1800
≤ 2094	≤ 1134	30	+3600/-2400	/	/	+1400/-1400	+3600/-2400	/	+5400/-2400	+1400/-1400	+1400/-1400	+1600/-1600	/	/	+1600/-1600
≤ 2279	≤ 1134	30	+2400/-2400	-	-	+1400/-1400	+2400/-2400	/	+5400/-2400	+1400/-1400	+1400/-1400	+1600/-1600	/	/	+1600/-1600
≤ 1755	≤ 1038	35	+5400/-2400	/	/	+2200/-2200	+5400/-2400	+1400/-1400	/	+2200/-2200	+2200/-2200	+2400/-2400	+1200/-1200	+1400/-1400	+2400/-2400
≤ 1925	≤ 1038	35	+5400/-2400	/	/	+2200/-2200	+5400/-2400	/	/	+2200/-2200	+2200/-2200	+2400/-2400	/	/	+2400/-2400
≤ 2094	≤ 1038	35	+3600/-2400	-	-	+2200/-2200	+3600/-2400	/	+5400/-2400	+2200/-2200	+2200/-2200	+2400/-2400	/	/	+2400/-2400
≤ 1760	≤ 1096	35	+5400/-2400	/	/	+2000/-2000	+5400/-2400	+1400/-1400	/	+2000/-2000	+2000/-2000	+2200/-2200	+1100/-1100	+1400/-1400	+2200/-2200
≤ 2186	≤ 1096	35	+3600/-2400	-	-	+1800/-1800	+3600/-2400	/	+5400/-2400	+1800/-1800	+1800/-1800	+2000/-2000	/	/	+2000/-2000
≤ 2384	≤ 1096	35	+2400/-2400	-	-	+1800/-1800	+2400/-2400	/	+5400/-2400	+1800/-1800	+1800/-1800	+2000/-2000	/	/	+2000/-2000
≤ 1724	≤ 1134	35	+5400/-2400	/	/	+2000/-2000	+5400/-2400	+1400/-1400	/	+2000/-2000	+2000/-2000	+2000/-2000	+1000/-1000	+1400/-1400	+2000/-2000
≤ 1910	≤ 1134	35	+5400/-2400	/	/	+2000/-2000	+5400/-2400	/	/	+2000/-2000	+2000/-2000	+2000/-2000	/	/	+2000/-2000
≤ 2094	≤ 1134	35	+3600/-2400	/	/	+1800/-1800	+3600/-2400	/	+5400/-2400	+1800/-1800	+1800/-1800	+2000/-2000	/	/	+2000/-2000
≤ 2279	≤ 1134	35	+2400/-2400	-	-	+1800/-1800	+2400/-2400	/	+5400/-2400	+1800/-1800	+1800/-1800	+2000/-2000	/	/	+2000/-2000
≤ 2465	≤ 1134	35	+2400/-2400	-	-	+1600/-1600	+2400/-2400	/	+5400/-2400	+1600/-1600	+1600/-1600	+1800/-1800	/	/	+1800/-1800
≤ 2172	≤ 1303	35	/	+2400/-2400	+3600/-2400	+1600/-1600	+3600/-2400	/	+5400/-2400	+1600/-1600	+1600/-1600	+1800/-1800	/	/	+1800/-1800
≤ 2384	≤ 1303	35	/	+2400/-2400	+2400/-2400	+1400/-1400	+2400/-2400	/	+5400/-2400	+1400/-1400	+1400/-1400	+1600/-1600	/	/	+1600/-1600
≤ 1755	≤ 1038	30	+5400/-2400	/	/	+2200/-2200	+5400/-2400	+1200/-1200	/	+2200/-2200	+2200/-2200	/	+1000/-1000	+1200/-1200	+2200/-2200
≤ 2094	≤ 1038	30	+3600/-2400	/	/	+2200/-2200	+3600/-2400	/	+5400/-2400	+2200/-2200	+2200/-2200	/	/	/	+2200/-2200
≤ 1812	≤ 1096	30	+5400/-2400	/	/	+2200/-2200	+5400/-2400	+1200/-1200	/	+2200/-2200	+2200/-2200	/	+1000/-1000	+1200/-1200	+2200/-2200
≤ 1900	≤ 1096	30	+5400/-2400	/	/	+2000/-2000	+5400/-2400	/	/	+2000/-2000	+2000/-2000	+2200/-2200	/	/	+2200/-2200
≤ 2172	≤ 1096	30	+3600/-2400	-	-	+2000/-2000	+3600/-2400	/	+5400/-2400	+2000/-2000	+2000/-2000	+2200/-2200	/	/	+2200/-2200
≤ 1724	≤ 1134	30	+5400/-2400	/	/	+2000/-2000	+5400/-2400	+1200/-1200	/	+2000/-2000	+2000/-2000	+2200/-2200	+1000/-1000	+1200/-1200	+2200/-2200
≤ 1910	≤ 1134	30	+5400/-2400	/	/	+2000/-2000	+5400/-2400	/	/	+2000/-2000		+2200/-2200	/	/	+2200/-2200
≤ 2094	≤ 1134	30	+3600/-2400	/	/	+1800/-1800	+3600/-2400	/	+5400/-2400	+1800/-1800	+1800/-1800	+2000/-2000	/	/	+2000/-2000
≤ 2279	≤ 1134	30	+2400/-2400	-	-	+1800/-1800	+2400/-2400	/	+5400/-2400	+1800/-1800	+1800/-1800	+2000/-2000	/	/	+2000/-2000
≤ 1755	≤ 1038	35	+5400/-2400	/	/	+2600/-2600	+5400/-2400	+1600/-1600	/	+2600/-2600	+2600/-2600	+2800/-2800	+1400/-1400	+1600/-1600	+2800/-2800
≤ 1925	≤ 1038	35	+5400/-2400	/	/	+2600/-2600	+5400/-2400	/	/	+2600/-2600	+2600/-2600	+2800/-2800	/	/	+2800/-2800
≤ 2094	≤ 1038	35	+3600/-2400	-	-	+2600/-2600	+3600/-2400	/	+5400/-2400	+2600/-2600	+2600/-2600	+2800/-2800	/	/	+2800/-2800
≤ 1760	≤ 1096	35	+5400/-2400	/	/	+2400/-2400	+5400/-2400	+1600/-1600	/	+2400/-2400	+2400/-2400	+2600/-2600	+1300/-1300	+1600/-1600	+2600/-2600
≤ 2186	≤ 1096	35	+3600/-2400	-	-	+2200/-2200	+3600/-2400	/	+5400/-2400	+2200/-2200	+2200/-2200	+2400/-2400	/	/	+2400/-2400
≤ 2384	≤ 1096	35	+3600/-2400	-	-	+2200/-2200	+3600/-2400	/	+5400/-2400	+2200/-2200	+2200/-2200	+2400/-2400	/	/	+2400/-2400
≤ 1724	≤ 1134	35	+5400/-2400	/	/	+2400/-2400	+5400/-2400	+1600/-1600	/	+2400/-2400	+2400/-2400	+2600/-2600	+1200/-1200	+1600/-1600	+2600/-2600
≤ 1910	≤ 1134	35	+5400/-2400	/	/	+2400/-2400	+5400/-2400	/	/	+2400/-2400	+2400/-2400	+2600/-2600	/	/	+2600/-2600
≤ 2094	≤ 1134	35	+3600/-2400	/	/	+2200/-2200	+3600/-2400	/	+5400/-2400	+2200/-2200	+2200/-2200	+2400/-2400	/	/	+2400/-2400
≤ 2279	≤ 1134	35	+3200/-2400	-	-	+2200/-2200	+3200/-2400	/	+5400/-2400	+2200/-2200	+2200/-2200	+2400/-2400	/	/	+2400/-2400
≤ 2465	≤ 1134	35	+2800/-2400	-	-	+2000/-2000	+2800/-2400	/	+5400/-2400	+2000/-2000	+2000/-2000	+2200/-2200	/	/	+2200/-2200
≤ 2172	≤ 1303	35	/	+2400/-2400	+3600/-2400	+2000/-2000	+3600/-2400	/	+5400/-2400	+2000/-2000	+2000/-2000	+2200/-2200	/	/	+2200/-2200
≤ 2384	≤ 1303	35	/	+2400/-2400	+3200/-2400	+1800/-1800	+3200/-2400	/	+5400/-2400	+1800/-1800	+1800/-1800	+2000/-2000	/	/	+2000/-2000

/" means "not applicable"  
 "-" means "must be check with OPENAX"

### 6. ELECTRICAL INSTALLATION

#### General Installation Guidelines

All wiring installation should be carried out by qualified installers in accordance with local electrical construction codes, procedures, and regulations.

- ☑ Any hardware used must be compatible with the mounting structure material to avoid galvanic corrosion. It is not recommended to use modules with different configurations (grounding, wiring) in the same system. For applications requiring a high operating voltage several modules can be connected in series to form a string of modules. The total voltage is the sum of voltages of all the modules.

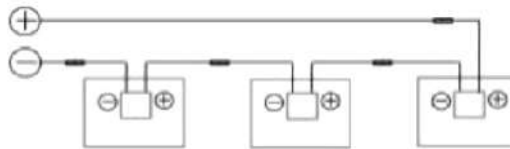

The maximum number of series connected modules depends on system design, the type of inverter used and environmental conditions. It must be calculated in accordance with applicable regulations. Make sure the open circuit voltage of string does not exceed the maximum system voltage of the modules and the other electrical DC modules required at the minimum temperature at the PV system location. The number of modules connected to an inverter should be within the inverter voltage limits and operating range. The maximum voltage of string does not exceed the maximum system voltage of the modules (system voltage of OPENAX solar modules is stated in the nameplate of the product and the datasheet).

- ☑ Using the following formula:
- ☑  $\text{System voltage} = N \cdot V_{oc} \cdot [1 + \lambda_{voc} (T_{min} - 25^\circ\text{C})]$
- ☑ N = number of modules in series
- ☑  $V_{oc}$  = open circuit voltage at STC (refer to product label or data sheet)
- ☑  $\lambda_{voc}$  = Thermal coefficient of  $V_{oc}$  of each module (refer to product data sheet)
- ☑  $T_{min}$  = minimum ambient temperature at the PV system location

For applications requiring high operating currents several strings of modules can be connected in parallel; the system current is then equal to the sum of the current of each string of modules.

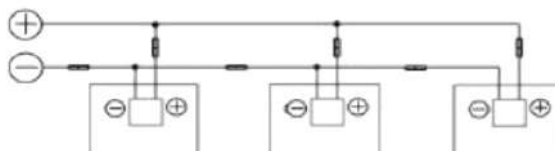

Bifacial modules increase energy and power production respect to STC nominal data through Albedo on rear surface. Refer to the specific area on data sheet for real parameters expected after installation to calculate correctly inverter, cables and connection size...

In the case of parallel connection a protection against excessive reverse currents must be installed. The maximum allowed reverse current is stated in the datasheet of each product.

- ☑ Under normal conditions, a photovoltaic module is likely to experience conditions that produce more current and/or voltage than reported at standard test conditions. Accordingly, the values of  $I_{sc}$  and  $V_{oc}$  marked on this module should be multiplied by a factor of 1.25 when determining component voltage ratings, conductor ampacities, fuse sizes, and size of controls connected to the PV output.
- ☑ All relevant electrical installation codes and regulations should be observed for regulations on working at heights and fall protection.
- ☑ The PV modules can be irreparably damaged if an array string is connected in reverse polarity to another. Always verify the voltage and polarity of each string before making a parallel connection. If a reversed polarity or a voltage difference of more than 10V between strings was detected, check the string configuration before connection.

### Cables, Connectors and Junction Box

- ☑ To prevent the cables and the connectors from overheating, the cross section of the cables and the capacity of the connectors must be selected to suit the maximum system short circuit current. For field connections, use minimum 4mm<sup>2</sup> copper wires insulated for an operating temperature of 85°C. Use connectors with an operating temperature of 105°C.
- ☑ The module junction box is rated IP67 or IP68 depending of the module type. Our modules are supplied with connectors to be used for system electrical connections.
- ☑ All connectors and cables must be securely fastened.
- ☑ They must also have UV resistance and approval for outside use. Secure cables using UV-resistant cable ties or other UV-resistant devices. Loose cables must be protected from abrasion, sharp objects, animals etc. Avoid exposing cables as far as possible to direct sunlight and permanent tension.
- ☑ Do not bend the cables less than 60 mm radius. PV cables will be damaged if bending radius less than 60. mm. (2.36 in).

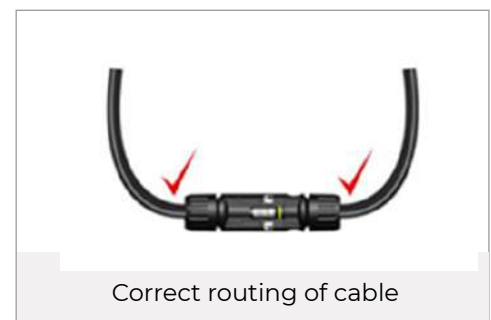
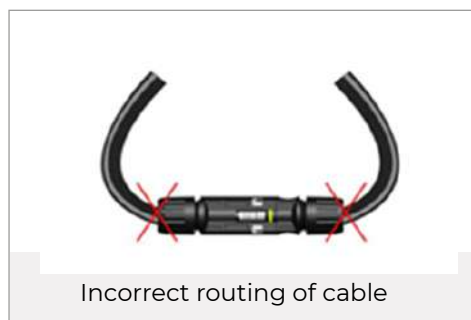
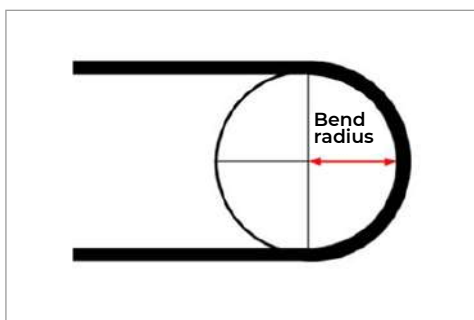

- ⊙ OPENAX Modules contain factory installed bypass diodes. If the Modules are incorrectly connected to each other, the bypass diodes, cables, or junction box may be damaged.
- ⊙ When reverse currents can exceed the value of the maximum protective fuse, a properly rated and certified over current device (fuse or circuit breaker) must be connected in series with each Module or string of Modules.
- ⊙ Match the polarities of cables and terminals when making the connections; failure to do so may result in damage to the Module.
- ⊙ Connecting Modules in reverse polarity to a high current source, such as a battery, will destroy the bypass diodes and render the Module inoperative. Bypass diodes are not user replaceable.
- ⊙ The junction box, cable and connectors shall not be altered in any case. Modules with a suspected electrical problem should be returned to OPENAX for inspection and possible repair or replacement as per the warranty policy shall be provided by OPENAX .
- ⊙ The DC current generated by photovoltaic systems can be converted into AC and fed into a public grid. As local utilities' policies on connecting renewable energy systems to their grids vary from region to region, a qualified system designer or integrator should always be consulted. Building permits, inspections and approvals by the local utility are generally required.

### Grounding

- ⊙ All module frames and mounting racks must be properly grounded in accordance with the electrical design and construction specifications, procedures, regulations and other special grounding requirements applicable to the installation sites.
- ⊙ The module is considered to be in compliance with this standard only when the module is mounted in the manner specified by the mounting instructions. A module with exposed conductive parts is considered to be in compliance with this standard only when it is electrically grounded in accordance with the manufacturer's instructions and the requirements of the National Electrical Code, ANSI/NFPA 70 (2014-2017)."
- ⊙ Module frames should be connected to an earth ground for safety and protection from lightning. A good connection between the grounding hardware is essential for an effective ground. The anodization on a Module frame provides a coating to minimize the corrosion due to weather and it acts as a barrier that reduces the effectiveness of the grounding connection. For an adequate ground, the grounding hardware should pierce the anodization layer.
- ⊙ Proper grounding is achieved by bonding the Module frame(s) and all metallic structural members together continuously using a suitable grounding conductor. The grounding conductor or strap may be copper, copper alloy, or any other material acceptable for use as an electrical conductor. The devices have to be installed in accordance with the grounding device manufacturer's specified instructions. The grounding must be cross verified for its proper continuity.
- ⊙ Note: - "Please avoid negative bias of the cells with respect to the grounded frames".
- ⊙ All work must be carried by authorized installers in conformance to State and local codes and electricity standards.
- ⊙ A 10 to 14 mm<sup>2</sup> copper wire (AWG 6~12) is recommended as a ground wire. The ground hole position of the assembly has the ground sign ".

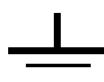

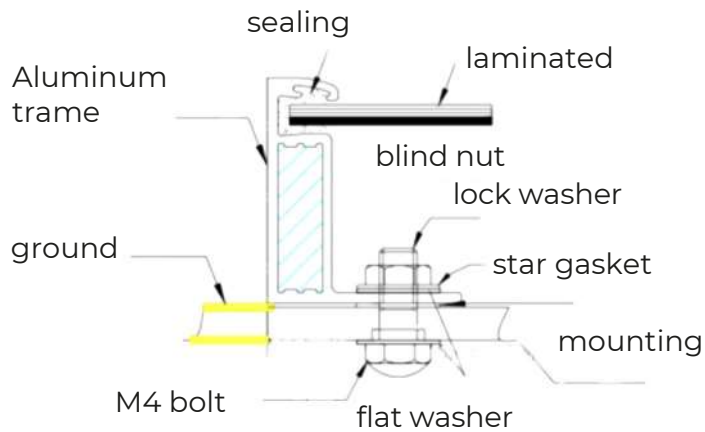

### PV module grounding methods

In addition to using grounding holes, you can choose the following methods:

- ☑ Earthing with unused mounting holes.
- ☑ Other special grounding devices.

#### Manufacturer's specified instructions

OPENAX recommend using the following methods to ground installation properly under UL investigation.

#### Method 1: Tyco grounding bolt # 2058729-

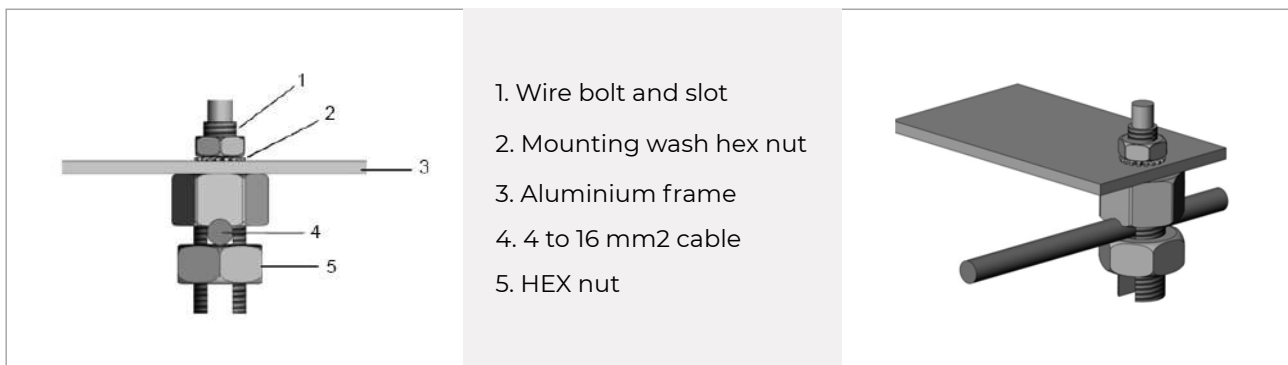
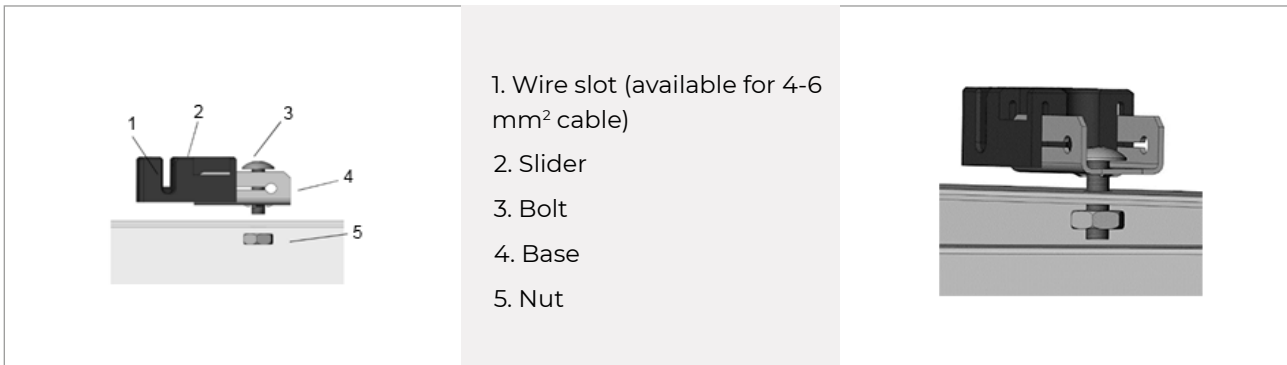

**Figure: Grounding bolt # 2058729-1**

Tyco grounding hardware comes in a package that includes the grounding bolt, mounting and grounding hex nut. Electrical contact is made by penetrating the anodized coating of the aluminium frame, and tightening the mounting hex nut (come with the star washer) to the proper torque of 25lbf.in. Grounding wire size (6 to 12 AWG solid bare copper) should be selected and installed underneath the wire binding bolt.

The wire binding bolt should be tightened to the proper torque of 45lbf.in.

### Method 2: Grounding bolt #1954381-2



**Figure: Grounding bolt # 1954381-2**

Tyco grounding hardware comes in a package that includes the grounding bolt, mounting and grounding hex nut. Electrical contact is made by penetrating the anodized coating of the aluminium frame, and tightening the mounting hex nut (come with the star washer) to the proper torque of 25 in lb. Grounding wire size (6 to 12 AWG solid bare copper) should be selected and installed underneath the wire binding bolt. The wire binding bolt should be tightened to the proper torque of 45 in lb. The Tyco grounding bolt is only listed for use with 6 to 12 AWG bare solid copper wire.

### Method 3: ERICO grounding bolt # EL6CS:

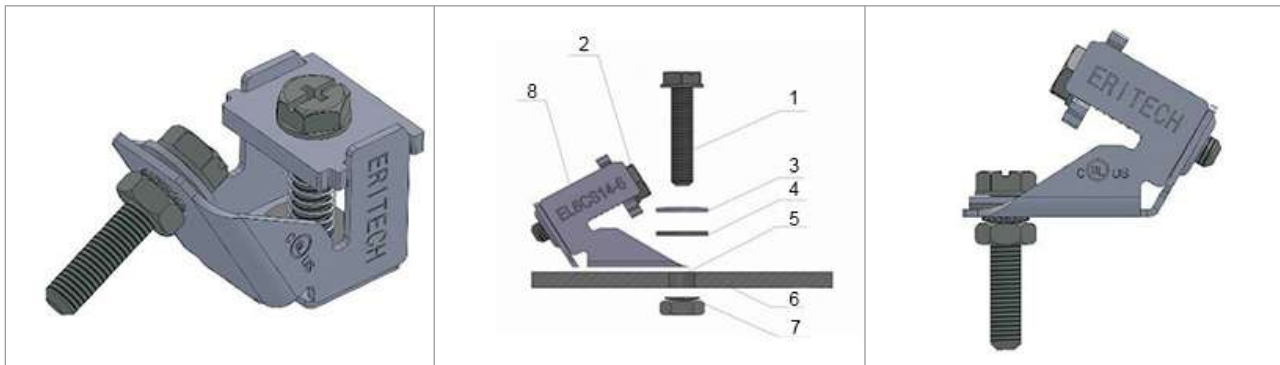

**Fig: ERICO grounding bolt # EL6CS**

- |                      |  |
|----------------------|--|
| 1. Machine bolt A    | 5. Clearance hole for #10[M5] machine bolt |
| 2. Machine bolt B    | 6. Aluminium frame                         |
| 3. Belleville washer | 7. Machine bolt hex nut with lock washer   |
| 4. Flat washer       | 8. Grounding bolt                          |

- ☑ The lug should be installed on a surface that is larger than the bottom surface of the lug.
- ☑ The lug should be installed in the grounding holes provided on the PV module.
- ☑ Machine bolt A should be torqued to 35 in lb, to secure the grounding bolt to module frame.
- ☑ The grounding bolt is only listed for use with 6-12 AWG bare solid copper wire.
- ☑ For proper wire binding, machine bolt B should be torqued to 35 in lb.

## 7. ELECTRICAL CONFIGURATION

Photovoltaic (electric) systems operate automatically and require very little day-to-day supervision. The solar array generates DC electricity whenever light falls on it similarly the inverter automatically turns ON as soon as there is sufficient energy from the solar array to efficiently convert this into grid.

**Caution :** Solar module is rated to operate at potentially lethal DC voltages which have the potential can cause severe electrical shock, arcing and fire hazards. Whilst some solar modules, manufactured by OPENAX , are certified to operate up to 1500 V DC always check the module Back label to confirm the actual rating of your product before making connections.

It is recommended to use a suitably rated isolator (DC switch) to interrupt the current flow before Disconnecting the connectors. Even after disconnecting, the DC power may be active for some time, hence only expert operators are recommended to operate upon the panels, string combiner box, etc. OPENAX will not be responsible for any electrical accidents occurring in power plants using OPENAX PV modules.

---

### Fuse

- ⌚ When fuses are fitted they should be rated for the maximum DC voltage and connected in each, Non-grounded pole of the array (i.e. if the system is not grounded then fuses should be connected in both the positive and negative poles). The maximum rating of a fuse connected in series with an array string is typically 25A but the actual module specific rating can be found on the product label and in the product datasheet.
- ⌚ This fuse rating value also corresponds to the maximum reverse current that a module can withstand (when one string is shaded then the other parallel strings of modules will be loaded by the shaded string and current will flow) and therefore impacts the number of strings in parallel.

---

### Inverter Selection and Compatibility

Only connect the quantity of modules that corresponds to the voltage specifications of the inverters used in the system. When installed as per IEC norms and regulations, OPENAX modules normally do not need to be electronically connected to earth and can operate with either galvanically isolated (with transformer) and transformer less inverters. If the system is located in hot and very humid locations then galvanically isolated Inverters with Transformers must be used and the negative pole of the array must be connected to earth. It is recommend to adopt inverter negatively earthed installation to avoid the PID effect. If a Transformer less Inverter is used in hot humid climatic locations, The Installer should ensure the right active negative earthing kit is to be installed by consulting and having assurance from the inverter supplier.

---

### Bypass Diodes

- ⌚ OPENAX Solar PV modules are equipped with bypass diodes in the junction box. This minimizes module heating and current losses. Do not try to open the junction box to change the diodes even if they malfunction.
- ⌚ In a system using a battery, blocking diodes are typically placed between the battery and the PV module output to prevent battery discharge at night.



## 8. MODULE SPECIFICATIONS

Note: For more details please refer to the latest datasheets uploaded on our website.

## 9. MAINTENANCE

To ensure optimum module performance, OPENAX recommends the following maintenance measures:

### Visual inspection

The modules must be inspected and maintained regularly, which is the responsibility of the users.

- ⊙ The circuit breaker should be disconnected before the inspection.
- ⊙ If the modules are damaged, such as broken glass, broken cables, and damaged junction boxes, it may cause functional and safety failures.
- ⊙ If the module is damaged, replace the damaged module with a new module of the same type.
- ⊙ Do not touch the live part of the cable or connector.

It is recommended to perform a preventive inspection every six months, and do not replace components of modules without authorization.

- ⊙ If electrical or mechanical performance inspection or maintenance is required, it is recommended that qualified professionals should perform the operation to avoid electric shock or personal injury.
- ⊙ The vegetation should be cut regularly to avoid shading and thus affecting the module's performance.
- ⊙ Check if the mounting hardware is tightened correctly in place.
- ⊙ Check whether all string fuses in each non grounded pole are working properly.



Modules exposed to sunlight can generate high voltage, which is extremely dangerous.

- ⊙ Make sure to isolate the impacted array string to prevent the current generation before attempting to remove the module.
- ⊙ Pay attention to other safety precautions listed at the beginning of this manual.

Inspect all cables to verify that they are firmly connected, avoid direct sunlight, and keep them away from water areas.

It is recommended to check the connectors, torque of bolts, and the general condition of wiring at least once a year. Loose connections will result in damage to the array.

### Cleaning

The amount of electricity generated by a PV module is proportional to the amount of light captured. A module with shaded cells generates less electrical energy, but increases the risk of overheating and hot spots, and may cause irreversible damage. Therefore, it is essential to keep PV modules clean. Dirt such as bird droppings, leaves, dust usually needs to be cleaned...



Cleaning activities create risk of damaging the modules and array components, as well as increasing the potential electric shock hazard. Cracked and broken modules represent an electric shock hazard due to leakage currents, and the risk of shock is increased when modules are wet. Before cleaning, thoroughly inspect modules for cracks, damage, and loose connection.

- ⊙ Cleaning of the modules shall be carried out by trained personnel to wear rubber gloves and working boots, and the protective equipment shall be able to withstand a DC working voltage of not less than 2,000 V.
- ⊙ Make sure that the array has been disconnected from other active components before starting the cleaning.
- ⊙ Always use clean, soft water and a soft sponge or cloth for cleaning.
- ⊙ A mild, non-abrasive cleaning agent (as conventional household glass cleaning agent) may be used to remove stubborn dirt.
- ⊙ Corrosive solvents (alkaline and strong acidic solvents, including hydrofluoric acid, alkali, acetone, etc) or hard objects are prohibited.
- ⊙ Do not immerse the modules partially or completely in water or any washing solution.
- ⊙ The modules shall be cleaned with irradiance below  $200\text{W} / \text{m}^2$ , like early in the morning, to avoid thermal shock and damage.
- ⊙ To prevent damage to the assembly, the water temperature must be similar ( $\pm 5^\circ\text{C}$ ) to the temperature of the PV modules.
- ⊙ Do not clean modules under the weather conditions of wind more than 4 class (in Beaufort scale), heavy rain or heavy snow.
- ⊙ When cleaning the modules, it is forbidden to step on the modules, forbidden the injection of water to the backside of the modules or cables. Please ensure that the connectors are clean and dry to prevent electric shock and fire hazards.
- ⊙ Do not use high pressure hoses, they may damage the module.
- ⊙ Do not use steam cleaner.
- ⊙ The back surface of the monofacial module usually does not need to be cleaned. When cleaning the back of the bifacial module, avoid any sharp objects that may cause damage or penetrate the base material. The other cleaning requirements are the same as the front-side.

### Method A: Wet cleaning

- ☑ Requirement for water quality: PH 5~7
- ☑ Chloride and salinity: 0~3000mg/L
- ☑ Turbidity: 0~30 NTU
- ☑ Conductivity: 1500~3000s/cm
- ☑ Total dissolved solids: 1000 mg/L
- ☑ Water hardness: 0~40mg/L
- ☑ Non-alkaline water should be used; deionized water should be used when conditions are available;
- ☑ If excessive soiling is present on the module surface, a non-conductive brush, sponge, or other mild agitating method may be used with caution.
- ☑ Please make sure that any brushes or agitating tools are constructed with non-conductive materials to minimize risk of electric shock and that they are not abrasive to the glass or the aluminum frame.
- ☑ If grease is present, an environmentally friendly cleaning agent may be used with caution.

### Method B: Compressed Air

This method is recommended to clean the soft dirt (like dust, sand) on modules. This technique can be applied as long as the method is efficient enough to clean the modules considering the on-site conditions.

After cleaning the PV modules, assembly inspection is required:

- ☑ Whether the overall appearance of the visual modules is clean, bright and stain-free.
- ☑ Check the PV modules surface for obvious scratch marks, cracks, breaks, etc...
- ☑ Whether the assembly bracket is inclined and bent after cleaning.
- ☑ Whether the PV modules terminals are loose or detached after cleaning.
- ☑ The cleaning transcript needs to be completed.

If you meet any problem, consult a professional for suggestions.

- ☑ Caution: observe the maintenance instructions for all components used in the system, such as support frames, charging regulators, inverters, batteries etc.

## 10. DISCLAIMER OF LIABILITY

- ☉ As the adherence to this manual and the conditions or methods of installation, operation, use and maintenance of photovoltaic (PV) products are beyond OPENAX 's control, OPENAX does not accept responsibility and expressly disclaims liability for any loss, damage, or expense arising out of or in any way connected with such installation, operation, use or maintenance.
- ☉ No responsibility is assumed by OPENAX for any infringement of patents or other rights of third parties, which may result from the use of the PV product. No license is granted by implication or otherwise under any patent or patent rights.
- ☉ The information in this manual is based on OPENAX 's best knowledge and experience and is believed to be reliable; but such information including product specification (without limitations) and suggestions do not constitute a warranty, express or implied. OPENAX reserves the right to change the manual, the PV product, the specifications, or product information sheets without prior notice.

## 11. DECOMMISSIONING AND RECYCLING

- ☉ The dismantling of PV systems must be performed with the same care and safety precautions used during the initial installation. The PV system can generate hazardous voltage even after the system has been disconnected. Follow safety regulations for working with live electrical equipment.
- ☉ OPENAX is a member of PV Cycle, the European association for voluntary take back and recycling of PV modules. Please contact PV Cycle at [www.pvcycle.org](http://www.pvcycle.org) for details regarding the recycling process.

## 12. PRODUCT INFORMATION

### Structural Drawings

Can be provided upon request at [technical@openax.com](mailto:technical@openax.com) or through the appointed account manager, along with the order number i.e. invoice number and/or any further needed information.



# AN APPROVED EXPERIENCE OVER TIME

---

## JOIN US

[www.openax.com](http://www.openax.com)

---

### OPENAX

8 RUE DE L'EST, 92100  
BOULOGNE-BILLANCOURT

[contact@openax.com](mailto:contact@openax.com)  
[www.openax.com](http://www.openax.com)

---

### OPENAX

16/18 rue Gustave Eiffel - Gretz Armainvilliers,  
France, 77220, France

[logistics@openax.com](mailto:logistics@openax.com)  
[contact@openax.com](mailto:contact@openax.com)  
[www.openax.com](http://www.openax.com)